

## EXPLOSION-PROOF PRESSURE, VACUUM, DIFFERENTIAL PRESSURE, TEMPERATURE SWITCHES



### FEATURES

- Class I, Div. 1 & 2, (Zone 1)  
Class II, Div. 1 & 2  
Class III
- Worldwide approvals and certifications
- Choice of one or two SPDT,  
optional DPDT output
- Dual electrical conduit openings
- Terminal block wiring
- Welded diaphragm or bellows sensor
- Ultra-low pressure ranges





### OVERVIEW

As safety requirements become more stringent, the determining factor in specifying an industrial pressure, differential pressure and/or temperature switch rests upon that switch protecting equipment, processes and personnel. Meeting hazardous location requirements through adherence to UL, CSA, and ATEX standards, UE's 120 Series is the choice where potentially explosive or highly corrosive atmospheres exist.

The 120 Series offers a variety of pressure, differential pressure, vacuum and temperature ranges, as well as port connections, wetted materials and sensor types. With common, flexible "platforms", models can quickly be adapted at the factory for special requirements, such as ranges, process connections and electrical ratings. Typical industries using 120 Series switches include chemical, petrochemical, refinery, oil and gas production and transmission, and pharmaceuticals.

An innovator in Threshold Detection and Switching™ technology since 1931, United Electric's primary focus remains the manufacture of switches and sensors for the protection of equipment, processes and people.

### FEATURES

- Approvals include cULus, ATEX, GOST, CQST, IECEx; compliance with CE and NACE standards
- Internal adjustment or external adjustment via calibrated dials with tamper resistant cover
- Integral cover lock
- Single or Dual Output
- Wide variety of sensor materials
- Optional Hastelloy® and Monel® sensor material for corrosive media
- Wide adjustable deadband models
- Flush mount sanitary sensors
- Stainless steel, Hastelloy®, and Monel® flanges conforming to ANSI standards
- Heat tracing and freeze protection temperature models
- Most models available for immediate delivery!

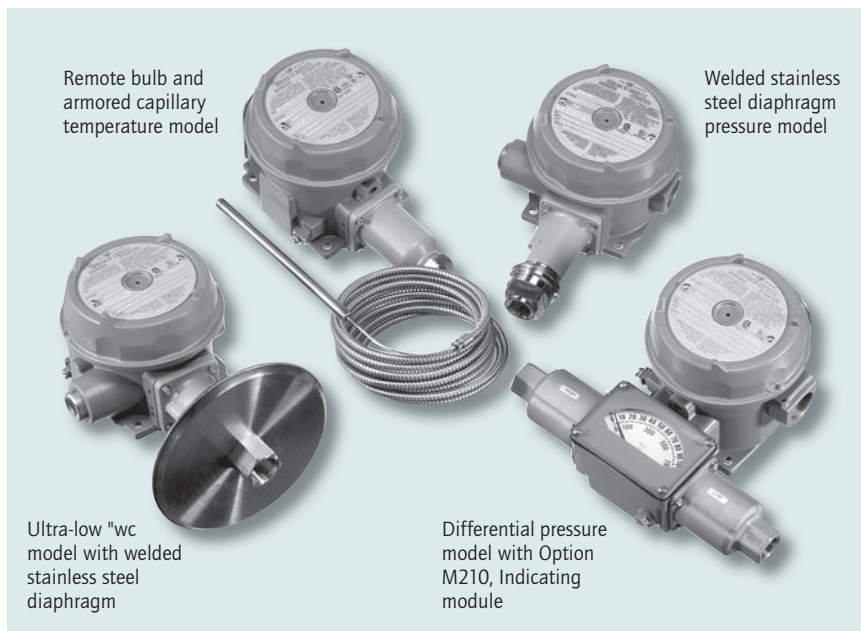

Remote bulb and armored capillary temperature model

Welded stainless steel diaphragm pressure model

Ultra-low "wc model with welded stainless steel diaphragm

Differential pressure model with Option M210, Indicating module

## SPECIFICATIONS

<b>STORAGE TEMPERATURE</b>	-65 to 160°F (-54 to 71°C)
<b>AMBIENT TEMPERATURE LIMITS</b>	-58 to 160°F (-50 to 71°C); models 36-39, 520-525, 540-548, 701-705: 0 to 160°F (-17 to 71°C); types 820E, 822E: -40 to 160°F (-40 to 71°C) set point typically shifts less than 1% of range for a 50°F (28°C) ambient temperature change; less than 2% for types E121& E122
<b>SET POINT REPEATABILITY</b>	Temperature models: Type B, C and F: ±1% of adjustable range Type E: ±2% of adjustable range  Pressure models 126-164, S126B-S164B, 171-174, 270-274, 358-376, 520-535, 540-543, 560-564, 701-705: ±1% of adjustable range; models 450-559: ±1/2% of adjustable range; models 36-39, 183-194, 483-494, 544-548, 565-567, 612-680: ±1-1/2% of adjustable range
<b>SHOCK</b>	Set point repeats after 15 G, 10 millisecond duration
<b>VIBRATION</b>	Set point repeats after 2.5 G, 5-500 Hz
<b>ENCLOSURE</b>	Die cast aluminum, epoxy powder coated; gasketed; coverlock; internal set point lock standard on types J, C, F; gasketed stainless steel tamper-resistant dial cover on types B, H, E; aluminum nameplate
<b>ENCLOSURE CLASSIFICATION</b>	Certified to enclosure type 4X. Class I, Division 1 product meets enclosure type 7; Class II, Division 1 product meets enclosure type 9. Certified to IP66 requirements
<b>SWITCH OUTPUT</b>	One or two SPDT; dual switch may be separated up to 100% of range; except type 822E where switch #2 can be set up to 25% of range span below switch #1 setpoint; switches may be wired "normally open" or "normally closed". Two SPDT hermetic sealed switches available on H122P models
<b>ELECTRICAL RATING</b>	15A 125/250/480 VAC resistive (standard) except types J120-15622, 15834-15839: 20A 125/250/480 VAC resistive; H122P; 11A 125/250 VAC resistive; B121-13272, B122-13322, E121-13273, E122-13321; 22A 480VAC resistive. Electrical switches have limited DC capabilities. Consult factory for additional information
<b>REFERENCE SCALES</b>	Types B, E & H: external dial. Scale divisions vary with range (see model charts)
<b>WEIGHT</b>	3-8 lbs. Varies with type and model
<b>ELECTRICAL CONNECTION</b>	Type H, B, E; one 3/4" NPT E/C; type J, C, F, 820E, 822E; two 3/4" NPT E/C; terminal block standard
<b>PRESSURE CONNECTION</b>	Models S126B-S164B, 171-194, 483-494, 520-535: 1/2" NPT (female); models 560-564: 2" sanitary connection; models 565-567: 1-1/2" sanitary connection; models 540-548: 1/8" NPT (female); all others: 1/4" NPT (female)
<b>TEMPERATURE ASSEMBLY</b>	Bulb and capillary: 6 feet 304 stainless steel (standard) except for E121-13273 and E122-13321: 10 feet; Immersion stem: nickel-plated brass (standard) except for B121-13272 and B122-13322: stainless steel. Fill: Model 1BS: solvent filled; models 2BS-8BS: non-toxic oil filled
<b>TEMPERATURE DEADBAND</b>	Type F120, 820E, 822E: typically 1%; type B-, C-, and E- 121 and 122: typically 2% of range under laboratory conditions (70°F [21°C] ambient circulating bath at rate of 1/2°F per minute change)
<b>PRESSURE DEADBAND</b>	<b>See Individual model charts</b>
<b>DIFFERENTIAL PRESSURE INDICATOR (OPTION M210)</b>	Differential pressure indication available types H121K and H122K with option M210 (check model availability under options); accuracy approximately 1% mid 50% of range, 3% at ends; window is plexiglass and gasketed; indicator may be field adjusted for approximately ±1% accuracy at any set point within range
<b>TEMPERATURE INDICATION</b>	Temperature indication available types 820E and 822E. Indication accuracy is ±1% of adjustable range

## AGENCY APPROVALS



### UNITED STATES AND CANADA

Class I, Division 1 and 2, Groups B, C & D  
 Class II, Division 1 and 2, Groups E, F & G  
 Class III  
 Class I, Zone 1, Group IIB + H2 T6  
 Enclosure Type 4X  
 UL Listed, cUL Certified  
 Pressure: UL 50 & 698; CSA C22.2  
 No. 25 & 30 - File # E40857  
 Temperature: UL 50 & 698; CSA C22.2  
 No. 25 & 30 - File # E43374



### EUROPE

#### ATEX Directive (94/9/EC)

II 2 G EEx d IIC T6  
 II 2 D T+85°C  
 Tamb = -40°C to +71°C, IP 66  
 UL International DEMKO A/S (N.B.# 0539)  
 Certificate # DEMKO 03 ATEX 0305048  
 EN 50014, 50018, 50281-1-1 & 60529



II 1 G EEx ia IIC T6 **(OPTIONAL - code M405)**  
 (not available types 820E, 822E)  
 Tamb = -50°C to +60°C  
 UL International DEMKO A/S (N.B.# 0539)  
 Certificate # DEMKO 03 ATEX 0335063  
 EN 50014, 50020 & 50284



#### Pressure Equipment Directive (PED) (97/23/EC)

Category IV, Module H1 **(OPTIONAL - code M407)**  
 (check options for model availability)  
 TÜV Süddeutschland Bau und Betrieb GmbH (N.B.# 0036)  
 Certificate # USA 02/04/38/001 thru USA 02/07/38/033  
 Products rated lower than 7.5 psi are outside the scope of the PED

#### Low Voltage Directive (LVD) (73/23/EC & 93/68/EEC)

UEC compliant to LVD  
 Products rated lower than 50 VAC and 75 VDC are outside of the scope of the LVD  
 The Low Voltage Directive does not apply to products for use in hazardous locations



### RUSSIA

#### Models 120, 121 and 122

Gosgortekhnadzor Permit **(OPTIONAL - code M406)**  
 0ExialICT6  
 Tamb = -50°C to +60°C  
 NANIO CCVE Certification Center  
 Certificate # RRS 00-22739  
 GOST R 51330.0, 51330.1, 51330.10 & 51330.14

#### Models 120, 121, 122, 820 & 822

1ExdIICT6X  
 Tamb = -56°C to +85°C (models 120, 121 & 122)  
 Tamb = -40°C to +71°C (models 820 & 822)  
 NANIO CCVE Certification Center  
 Certificate # RRS 00-22739  
 GOST R 51330.0, 51330.1, 51330.10 & 51330.14



### UKRAINE

Gosnadzorhrantruda Permit **(OPTIONAL - code M404)**  
 1ExdIICT6X  
 Tamb = -56°C to +85°C (types 120, 121 & 122)  
 Tamb = -40°C to +71°C (types 820 & 822)  
 Certificate # 1867.04.30 - 31.62.4

### CHINA

CQST Certified **(OPTIONAL - code M408)**  
 Exd IIC T6  
 DIP A21 TA +85°C  
 Tamb. = -40°C to +75°C  
 GB 3836.1, 3836.2 & 12476.1  
 Pressure: Certificate # CNEx 04.300X  
 Temperature: Certificate # CNEx 04.301X



### GLOBAL CERTIFICATION\* (INCLUDES AUSTRALIA)

IECEx Certified **(OPTIONAL - code M403)**  
 Ex d IIC T6  
 Tamb. = -40°C to 75°C  
 IEC 60079-0 & 60079-1  
 Certificate # IECEx UL 03.0001

\* See <http://www.iecex.com/countries.htm> for a list of participating members.

## PRESSURE MODEL CHART

## • Type J120, single switch with internal adjustment, dual conduits

Model	Adjustable Set Point Range		Deadband		Over Range Pressure*		Proof Pressure**	
	Low end of range on fall; High end of range on rise		"wc	mbar	psi	bar	psi	bar
	"wc	mbar						
Buna N diaphragm and O-Ring with epoxy coated aluminum, 1/2" NPT (female) pressure connection, large 0.72" orifice for clean-out purposes (other wetted materials available see pg. 16)								
520	300 Vac to 0	-746,7 to 0	0.2 to 8	0,5 to 19,9	200	13,8	400	27,6
521	10 Vac to 10	-24,9 to 24,9	0.1 to 0.6	0,2 to 1,5	200	13,8	400	27,6
522	50 Vac to 50	-124,5 to 124,5	0.1 to 3	0,2 to 7,5	200	13,8	400	27,6
523	0.5 to 5	1,2 to 12,4	0.1 to 0.3	0,2 to 0,7	200	13,8	400	27,6
524	2.5 to 50	6,2 to 124,5	0.1 to 0.8	0,2 to 2,0	200	13,8	400	27,6
525	10 to 250	24,9 to 622,3	0.1 to 6	0,2 to 14,9	200	13,8	400	27,6
Welded 316L stainless steel diaphragm and 1/2" NPT (female) pressure connection, large 0.72" orifice for clean-out purposes								
530	300 Vac to 0	-746,7 to 0	0.2 to 15	0,5 to 37,3	50	3,4	100	6,9
531	10 Vac to 10	-24,9 to 24,9	0.1 to 0.6	0,2 to 1,5	50	3,4	100	6,9
532	50 Vac to 50	-124,5 to 124,5	0.1 to 3	0,2 to 7,5	50	3,4	100	6,9
533	0.5 to 5	1,2 to 12,4	0.1 to 0.3	0,2 to 0,7	50	3,4	100	6,9
534	2.5 to 50	6,2 to 124,5	0.1 to 0.8	0,2 to 2,0	50	3,4	100	6,9
535	10 to 250	24,9 to 622,3	0.1 to 10	0,2 to 24,9	50	3,4	100	6,9
	psi	bar (unless noted)	psi	mbar (unless noted)	psi	bar	psi	bar
2" sanitary welded 316L stainless steel diaphragm and pressure connection. Mates with Tri-Clamp® fitting systems, (not UE supplied)								
560	0.5 to 15	34,5 mbar to 1,0 bar	0.1 to 1	6,9 to 68,9	200	13,8	300	20,7
561	1 to 25	68,9 mbar to 1,7 bar	0.1 to 1.5	6,9 to 103,4	200	13,8	300	20,7
562	2 to 50	0,1 to 3,4	0.1 to 2.5	6,9 to 172,4	200	13,8	300	20,7
563	4 to 100	0,3 to 6,9	0.1 to 4	6,9 to 275,8	200	13,8	300	20,7
564	8 to 200	0,6 to 13,8	0.1 to 5	6,9 to 344,7	200	13,8	300	20,7
1.5" sanitary welded 316L stainless steel diaphragm and pressure connection. Mates with Tri-Clamp® fitting systems, (not UE supplied)								
565	5 to 30	0,3 to 2,1	1 to 5	68,9 mbar to 0,3 bar	1000	68,9	1500	103,4
566	10 to 100	0,7 to 6,9	1 to 12	68,9 mbar to 0,8 bar	1000	68,9	1500	103,4
567	15 to 300	1,0 to 20,7	3 to 22	0,2 to 1,5	1000	68,9	1500	103,4
Welded 316L stainless steel diaphragm and 1/2" NPT (female) pressure connection, large 0.72" orifice for clean-out purposes (NACE MR-0175 compliant)								
171	1 to 20	68,9 mbar to 1,4 bar	0.1 to 1	6,9 to 68,9	500	34,5	1000	68,9
172	2 to 50	0,1 to 3,4	0.1 to 1.5	6,9 to 103,4	500	34,5	1000	68,9
173	4 to 100	0,3 to 6,9	0.1 to 2.5	6,9 to 172,4	500	34,5	1000	68,9
174	8 to 200	0,6 to 13,8	0.1 to 3.5	6,9 to 241,3	500	34,5	1000	68,9

**Application Note:** The use of metallic diaphragms where higher pressure shock or heavy cycling is expected should be avoided. Models 171-174 should not be used where system or start-up vacuum might exceed 26 " Hg Vac

**\*Over Range Pressure:** The maximum pressure that may be applied continuously without causing damage and maintaining set point repeatability.

**\*\*Proof Pressure:** The maximum pressure to which a pressure sensor may be occasionally subjected, which causes no permanent damage. The unit may require calibration (e.g. start-up, testing)



## PRESSURE MODEL CHART

### • Type J120, single switch with internal adjustment, dual conduits (cont.)

Model	Adjustable Set Point Range		Deadband		Over Range Pressure*		Proof Pressure**	
	Low end of range on fall; High end of range on rise		psi	bar	psi	bar	psi	bar
	(unless noted)	(unless noted)	(unless noted)	(unless noted)	(unless noted)	(unless noted)	(unless noted)	(unless noted)
316L stainless steel diaphragm (optional Hastelloy® C or Monel®); Viton® GLT O-Ring (optional Kalrez®, Silicone, Ethylene Propylene or Aflas®); 316 stainless steel 1/2" NPT (female) pressure connection (optional Hastelloy® C or Monel®), 0.72" orifice for clean-out purposes. Models 188 and 189 have a 316L stainless steel 1/2" NPT (female) pressure connection (NACE MR-0175 compliant)								
183	1 to 20	0,1 to 1,4	0.3 to 2.5	20,7 to 172,4 mbar	500	34,5	1000	68,9
184	2 to 50	0,1 to 3,4	0.3 to 3	20,7 to 206,8 mbar	500	34,5	1000	68,9
185	4 to 100	0,3 to 6,9	0.5 to 6	34,5 to 413,7 mbar	500	34,5	1000	68,9
186	8 to 200	0,6 to 13,8	1 to 11	0,1 to 0,8	500	34,5	1000	68,9
188	50 to 1000	3,4 to 68,9	25 to 125	1,7 to 8,6	2000	137,9	7000	482,6
189	250 to 3500	17,2 to 241,3	50 to 300	3,4 to 20,7	4000	275,8	7000	482,6
316L stainless steel diaphragm (optional Hastelloy® C or Monel®); Viton®GLT O-Ring (optional Kalrez®, Silicone, Ethylene Propylene or Aflas®); 316 stainless steel 1/2" NPT (female) pressure connection (optional Hastelloy® C or Monel®), 0.06" orifice to dampen pulsations. Models 488 and 489 have a 316L stainless steel 1/2" NPT (female) pressure connection (NACE MR-0175 compliant)								
483	1 to 20	0,1 to 1,4	0.3 to 2.5	20,7 to 172,4 mbar	500	34,5	1000	68,9
484	2 to 50	0,1 to 3,4	0.3 to 3	20,7 to 206,8 mbar	500	34,5	1000	68,9
485	4 to 100	0,3 to 6,9	0.5 to 6	34,5 to 413,7 mbar	500	34,5	1000	68,9
486	8 to 200	0,6 to 13,8	1 to 11	0,1 to 0,8	500	34,5	1000	68,9
488	50 to 1000	3,4 to 68,9	25 to 125	1,7 to 8,6	2000	137,9	7000	482,6
489	250 to 3500	17,2 to 241,3	50 to 300	3,4 to 20,7	4000	275,8	7000	482,6
Welded 316L stainless steel bellows and 1/2" NPT (female) pressure connection								
S126B	30 to 3 "Hg Vac	-1 to -0,1	0.2 to 0.6 "Hg	6,8 to 20,3 mbar	80 "wc	199,1 mbar	5	0,3
S134B	30 "Hg Vac to 20 psi	-1 to 1,4	0.2 to 0.6 "Hg	6,8 to 20,3 mbar	20	1,4	25	1,7
S137B	15 to 80 "wc	37,3 to 199,1 mbar	2 to 6 "wc	5,0 to 14,9 mbar	80 "wc	199,1 mbar	5	0,3
S144B	0.5 to 20	34,5 mbar to 1,4 bar	0.1 to 0.3	6,9 to 20,7 mbar	20	1,4	25	1,7
S152B	1 to 50	0,1 to 3,4	0.1 to 0.5	6,9 to 34,5 mbar	50	3,4	75	5,2
S156B	2 to 100	0,1 to 6,9	0.2 to 0.6	13,8 to 41,4 mbar	100	6,9	125	8,6
S164B	4 to 200	0,3 to 13,8	0.2 to 1	13,8 to 68,9 mbar	200	13,8	200	13,8

**Viton®** is a registered trademark of Dupont Dow Elastomers  
**Hastelloy®** is a registered trademark of Haynes International, Inc  
**Monel®** is a registered trademark of the INCO family of companies

**Kalrez®** and **Teflon®** are registered trademarks of E.I. Dupont  
**Aflas®** is a registered trademark of Asahi Glass  
**Tri-Clamp®** is a registered trademark of Tri-Clover, Inc.

## PRESSURE MODEL CHART

## • Type J120, single switch with internal adjustment, dual conduits (cont.)

Model	Adjustable Set Point Range		Deadband				Over Range Pressure*		Proof Pressure**	
	Low end of range on fall; High end of range on rise		Lower 75% range span		Top 25% range span		psi	bar	psi	bar
	psi	bar	psi	bar	psi	bar				
Welded 316 stainless steel diaphragm and 1/2" NPT (female) pressure connection, large 0.72" orifice for clean-out purposes (NACE MR-0175 compliant)										
190	5 to 30	0,3 to 2,1	1 to 3	0,1 to 0,2	6 max	0,4	1500	103,4	2500	172,4
191	10 to 100	0,7 to 6,9	1 to 8	0,1 to 0,6	15 max	1,0	1500	103,4	2500	172,4
192	15 to 300	1,0 to 20,7	3 to 18	0,2 to 1,2	25 max	1,7	1500	103,4	2500	172,4
193	20 to 500	1,4 to 34,5	4 to 30	0,3 to 2,1	45 max	3,1	1500	103,4	2500	172,4
194	80 to 1700	5,5 to 117,2	5 to 120	0,3 to 8,3	150 max	10,3	2000	137,9	2500	172,4
Welded 316 stainless steel diaphragm and 1/2" NPT (female) pressure connection, 0.06" orifice to dampen pulsations										
490	5 to 30	0,3 to 2,1	1 to 3	0,1 to 0,2	6 max	0,4	1500	103,4	2500	172,4
491	10 to 100	0,7 to 6,9	1 to 8	0,1 to 0,6	15 max	1,0	1500	103,4	2500	172,4
492	15 to 300	1,0 to 20,7	3 to 18	0,2 to 1,2	25 max	1,7	1500	103,4	2500	172,4
493	20 to 500	1,4 to 34,5	4 to 30	0,3 to 2,1	45 max	3,1	1500	103,4	2500	172,4
494	80 to 1700	5,5 to 117,2	5 to 120	0,3 to 8,3	150 max	10,3	2000	137,9	2500	172,4

Model	Adjustable Set Point Range		Deadband		Over Range Pressure*		Proof Pressure**			
	Low end of range on fall; High end of range on rise		psi (unless noted)	bar (unless noted)	psi (unless noted)	bar (unless noted)	psi (unless noted)	bar (unless noted)	psi	bar
	psi (unless noted)	bar (unless noted)								
Brass bellows with nickel-plated brass 1/4" NPT (female) pressure connection; models 126 & 134 have zinc-plated steel spring which is exposed to media										
126	30 to 3 "Hg Vac	-1 to 0,1	0.2 to 0.6 "Hg	6,8 to 20,3 mbar	80 "wc	199,1 mbar	5	0,3		
134	30 "Hg Vac to 20 psi	-1 to 1,4	0.2 to 0.6 "Hg	6,8 to 20,3 mbar	20	1,4	25	1,7		
137	15 to 80 "wc	37,3 to 199,1 mbar	2 to 6 "wc	5,0 to 14,9 mbar	80 "wc	199,1 mbar	5	0,3		
144	0.5 to 20	34,5 mbar to 1,4 bar	0.1 to 0.3	6,9 to 20,7 mbar	20	1,4	25	1,7		
152	1 to 50	0,1 to 3,4	0.1 to 0.5	6,9 to 34,5 mbar	50	3,4	75	5,2		
156	2 to 100	0,1 to 6,9	0.2 to 0.6	13,8 to 41,4 mbar	100	6,9	125	8,6		
164	4 to 200	0,3 to 13,8	0.2 to 1	13,8 to 68,9 mbar	200	13,8	200	13,8		
Welded 316L stainless steel bellows and 1/4" NPT (female) pressure connection										
356	15 to 100	1,0 to 6,9	0.7 to 1.8	48,3 to 124,1 mbar	100	6,9	800	55,2		
358	15 to 200	1,0 to 13,8	1 to 3	0,1 to 0,2	200	13,8	800	55,2		
361	20 to 300	1,4 to 20,7	1 to 4	0,1 to 0,3	300	20,7	800	55,2		
376	25 to 500	1,7 to 34,5	1.5 to 5	0,1 to 0,3	500	34,5	800	55,2		
Phosphor bronze bellows with nickel-plated brass 1/4" NPT (female) pressure connection										
270	4 to 200	0,3 to 13,8	1 to 4	0,1 to 0,3	200	13,8	250	17,2		
274	6 to 300	0,4 to 20,7	1 to 5	0,1 to 0,3	300	20,7	350	24,1		

**\*Over Range Pressure:** The maximum pressure that may be applied continuously without causing damage and maintaining set point repeatability.

**\*\*Proof Pressure:** The maximum pressure to which a pressure sensor may be occasionally subjected, which causes no permanent damage. The unit may require calibration (e.g. start-up, testing)

**Deadband note:** Models 190-194, 490-494 are expressed as the lower 75 % and top 25% of the range span because of the operating characteristics of the diaphragm sensor and switch.



## PRESSURE MODEL CHART

### • Type J120, single switch with internal adjustment, dual conduits (cont.)

Model	Adjustable Set Point Range		Deadband		Over Range Pressure*		Proof Pressure**	
	psi (unless noted)	bar (unless noted)	psi (unless noted)	bar (unless noted)	psi (unless noted)	bar (unless noted)	psi	bar
303 stainless steel piston with Buna N O-Ring and 303 stainless steel 1/4" NPT (female) pressure connection (not recommended for gas service since drying of the O-Ring seal can allow bleeding of medium into the atmosphere)								
612	125 to 3000	8,6 to 206,8	40 to 250	2,8 to 17,2	6000	413,7	10000	689,5
616	700 to 5000	48,3 to 344,7	40 to 375	2,8 to 25,9	6000	413,7	10000	689,5
316 stainless steel bellows and 1/4" NPT (female) pressure connection (not recommended for rapid or high cycling pressure changes)								
680	100 to 1700	6,9 to 117,2	9 to 40	0,6 to 2,8	1700	117,2	2500	172,4
Buna N diaphragm and O-Ring with nickel-plated brass 1/4" NPT (female) pressure connection; Optional Viton diaphragm and O-Ring available								
701	1.5 to 30	103,4 mbar to 2,1 bar	1 to 2	68,9 mbar to 0,1 bar	500	34,5	1000	68,9
702	3 to 100	0,2 to 6,9	1 to 4	68,9 to 0,3 bar	500	34,5	1000	68,9
703	9 to 300	0,6 to 20,7	1 to 5	68,9 to 0,3 bar	500	34,5	1000	68,9
704	15 to 500	1,0 to 34,5	2 to 8	0,1 to 0,6	1500	103,4	2500	172,4
705	30 to 1000	2,1 to 68,9	3 to 20	0,2 to 1,4	1500	103,4	2500	172,4
Buna N diaphragm and O-Ring with 1/4" NPT (female) aluminum connection and cap								
450	30 "Hg Vac to 3 "Hg Vac	-1 to -0,1	0.1 to 0.3 "Hg	3,4 to 10,2 mbar	80 "wc	199,1 mbar	225	15,5
451	2 to 80" wc	5 to 199,1 mbar	0.8 to 2 "wc	2 to 5 mbar	80 "wc	199,1 mbar	225	15,5
452	30 "Hg Vac to 20 psi	-1,0 to 1,4	0.1 to 0.4 "Hg	3,4 to 13,5 mbar	20	1,4	225	15,5
453	0.5 to 20	34,5 mbar to 1,4 bar	0.05 to 0.1	3,4 to 6,9 mbar	20	1,4	225	15,5
454	0.8 to 30	55,2 mbar to 2,1 bar	0.05 to 0.2	3,4 to 13,8 mbar	30	2,1	225	15,5
Teflon® diaphragm and O-Ring 316 stainless steel with 1/4" NPT (female) 316 stainless steel pressure connection and cap								
550	30 "Hg Vac to 3 "Hg Vac	-1 to -0,1	0.1 to 0.4 "Hg	3,4 to 13,5 mbar	80 "wc	199,1 mbar	225	15,5
551	2 to 80 "wc	5 to 199,1 mbar	1 to 4 "wc	2,5 to 10 mbar	80 "wc	199,1 mbar	225	15,5
552	30 "Hg Vac to 20 psi	-1,0 to 1,4	0.2 to 0.5 "Hg	6,8 to 16,9 mbar	20	1,4	225	15,5
553	0.5 to 20	34,5 mbar to 1,4 bar	0.1 to 0.2	6,9 to 13,8 mbar	20	1,4	225	15,5
554	0.8 to 30	55,2 mbar to 2,1 bar	0.1 to 0.3	6,9 to 20,7 mbar	30	2,1	225	15,5
555	2 to 100	0,1 to 6,9	0.2 to 0.4	13,8 to 27,6 mbar	100	6,9	225	15,5

Teflon® is a registered trademark of E.I. DuPont

\*Over Range Pressure: The maximum pressure that may be applied continuously without causing damage and maintaining set point repeatability.

\*\*Proof Pressure: The maximum pressure to which a pressure sensor may be occasionally subjected, which causes no permanent damage. The unit may require calibration (e.g. start-up, testing)

## PRESSURE MODEL CHART

- Type J120, single switch with internal adjustment, dual conduits with adjustable deadband mirco-switch

Model	Adjustable Set Point Range		Adjustable Deadband						Over Range Pressure*		Proof Pressure**	
	Low end of range on fall; High end of range on rise		psi		bar		(unless noted)		psi	bar	psi	bar
	psi	bar	psi	bar	psi	bar	psi	bar	psi	bar	psi	bar
Viton® diaphragm and O-ring with 1/4" NPT (female) 303 stainless steel pressure connection												
15622	20 to 200	1,4 to 13,8	12 to 26	0,8 to 1,8					500	34,5	1000	68,9
	psi	bar	psi	bar	psi	bar	psi	bar	psi	bar	psi	bar
Buna N diaphragm and O-Ring with nickel-plated brass 1/4" NPT (female) pressure connection												
15834	3 to 30	0,2 to 2,1	1.5 to 4	0,1 to 0,3	2 to 4.5	0,1 to 0,3	2.5 to 5	0,2 to 0,3	500	34,5	1000	68,9
15835	5 to 100	0,3 to 6,9	3 to 6	0,2 to 0,4	4 to 75	0,3 to 0,5	5 to 9	0,3 to 0,6	500	34,5	1000	68,9
15836	9 to 300	0,6 to 27	4 to 11	0,3 to 0,8	5 to 13	0,3 to 0,9	5 to 16	0,3 to 1,1	500	34,5	1000	68,9
15837	15 to 500	1 to 34,5	8 to 25	0,6 to 1,7	9 to 28	0,6 to 1,9	10 to 31	0,7 to 2,1	1500	103,4	2500	172,4
15838	30 to 1000	2,1 to 68,9	9 to 30	0,6 to 2,1	10 to 35	0,7 to 2,4	30 to 90	2,1 to 6,2	1500	103,4	2500	172,4
15839	100 to 1700	6,9 to 117,2	25 to 60	1,7 to 4,1	40 to 80	2,8 to 5,5	50 to 100	3,4 to 6,9	2000	137,9	2500	172,4

\***Over Range Pressure:** The maximum pressure that may be applied continuously without causing damage and maintaining set point repeatability.

\*\***Proof Pressure:** The maximum pressure to which a pressure sensor may be occasionally subjected, which causes no permanent damage. The unit may require calibration (e.g. start-up, testing)

## PRESSURE MODEL CHART

- **Type H121, single switch with external adjustment via reference dial, single conduit**
- **Type H122, dual switch with external adjustment via reference dial, single conduit**

Model	Adjustable Set Point Range		Deadband		Proof Pressure**		Dial Divisions
	psi (unless noted)	bar (unless noted)	psi (unless noted)	bar (unless noted)	psi	bar	psi (unless noted)
Welded 316L stainless steel bellows and 1/2" NPT (female) pressure connection							
S126B	30 "Hg Vac to 0 psi	-1 to 0	0.2 to 0.9 "Hg	6,8 to 30,5 mbar	5	0,3	0.5 "Hg
S134B	30 "Hg Vac to 20 psi	-1 to 1,4	0.2 to 1.2 "Hg	6,8 to 40,6 mbar	25	1,7	1 "Hg & 0.5 psi
S137B†	2 to 80 "wc	5 to 199,1 mbar	2 to 10 "wc	5 to 24,9 mbar	5	0,3	2 "wc
S144B	0 to 20	0 to 1,4	0.1 to 0.5	6,9 to 34,5 mbar	25	1,7	0.5
S146B	0 to 30	0 to 2,1	0.1 to 0.6	6,9 to 41,4 mbar	40	2,8	0.5
S156B	0 to 100	0 to 6,9	0.2 to 0.8	13,8 to 55,2 mbar	125	8,6	2
S164B	0 to 200	0 to 13,8	0.3 to 2	20,7 to 137,9 mbar	200	13,8	5
Brass bellows with nickel-plated brass 1/4" NPT (female) pressure connection; models 126 & 134 have a zinc-plated steel spring which is exposed to media							
126	30 "Hg Vac to 0 psi	-1 to 0	0.2 to 0.9 "Hg	6,8 to 30,5 mbar	5	0,3	0.5 "Hg
134	30 "Hg Vac to 20 psi	-1 to 1,4	0.2 to 1.2 "Hg	6,8 to 40,6 mbar	25	1,7	1 "Hg & 0.5 psi
137†	2 to 80 "wc	5 to 199,1 mbar	2 to 10 "wc	5 to 24,9 mbar	5	0,3	2 "wc
144	0 to 20	0 to 1,4	0.1 to 0.5	6,9 to 34,5 mbar	25	1,7	0.5
146	0 to 30	0 to 2,1	0.1 to 0.6	6,9 to 41,4 mbar	40	2,8	0.5
156	0 to 100	0 to 6,9	0.2 to 0.8	13,8 to 55,2 mbar	125	8,6	2
164	0 to 200	0 to 13,8	0.3 to 2	20,7 to 137,9 mbar	200	13,8	5
316L stainless steel bellows and 1/4" NPT (female) pressure connection							
358	0 to 200	0 to 13,8	1.5 to 8	0,1 to 0,6	250	17,2	5
361	0 to 300	0 to 20,7	2 to 9	0,1 to 0,6	350	24,1	10
376	0 to 500	0 to 34,5	3 to 12	0,2 to 0,8	575	39,6	10
303 stainless steel piston with Buna N O-Ring and 303 stainless steel 1/4" NPT (female) pressure connection (not recommended for gas service since drying of the O-Ring seal can allow bleeding of medium into the atmosphere)							
612	200 to 3000	13,8 to 206,8	40 to 250	2,8 to 17,2	10,000	689,5	50
614	500 to 6000	34,5 to 413,7	50 to 400	3,4 to 27,6	10,000	689,5	100

\*\***Proof Pressure:** The maximum pressure to which a pressure sensor may be occasionally subjected, which causes no permanent damage. The unit may require calibration (e.g. start-up, testing)

† Not available on type H122

## PRESSURE MODEL CHART

- **Type H121, single switch with external adjustment via reference dial, single conduit**
- **Type H122, dual switch with external adjustment via reference dial, single conduit**

Model	Adjustable Set Point Range		Deadband		Proof Pressure**		Dial Divisions
	psi (unless noted)	bar	psi (unless noted)	bar (unless noted)	psi	bar	psi (unless noted)
Phosphor bronze bellows with nickel-plated brass 1/4" NPT (female) pressure connection							
270	0 to 200	0 to 13,8	1.5 to 8	0,1 to 0,6	250	17,2	5
274	0 to 300	0 to 20,7	2 to 10	0,1 to 0,7	350	24,1	10
Buna N diaphragm and O-Ring with aluminum 1/4" NPT (female) pressure connection and cap							
450	30 "Hg Vac to 0 psi	-1 to 0	0.1 to 0.4 "Hg	3,4 to 13,5 mbar	225	15,5	0.5 "Hg
452	30 "Hg Vac to 20 psi	-1 to 1,4	0.1 to 1 "Hg	3,4 to 33,9 mbar	225	15,5	1 "Hg & 0.5 psi
453	0 to 20	0 to 1,4	0.05 to 0.2	3,4 to 13,8 mbar	225	15,5	0.5
454	0 to 30	0 to 2,1	0.05 to 0.3	3,4 to 20,7 mbar	225	15,5	0.5
Teflon® diaphragm and O-Ring with 316 stainless steel 1/4" NPT (female) pressure connection and cap							
550	30 "Hg Vac to 0 psi	-1 to 0,	0.1 to 0.6 "Hg	3,4 to 20,3 mbar	225	15,5	0.5 "Hg
552	30 "Hg Vac to 20 psi	-1 to 1,4	0.2 to 1 "Hg	6,8 to 33,9 mbar	225	15,5	1 "Hg & 0.5 psi
553	0 to 20	0 to 1,4	0.05 to 0.3	3,4 to 20,7 mbar	225	15,5	0.5
554	0 to 30	0 to 2,1	0.1 to 0.4	6,9 to 27,6 mbar	225	15,5	0.5
555	0 to 100	0 to 6,9	0.25 to 0.75	17,2 to 51,7 mbar	225	15,5	2
Buna N diaphragm and O-Ring with nickel-plated brass 1/4" NPT (female) pressure connection; Optional Viton diaphragm and O-Ring available (models 701-703)							
701†	3 to 30	0,2 to 2,1	1 to 3	0,1 to 0,2	1000	68,9	0.5
702	10 to 100	0,7 to 6,9	1 to 5	0,1 to 0,3	1000	68,9	2
703	30 to 300	2,1 to 20,7	2 to 7	0,1 to 0,5	1000	68,9	10
704	50 to 500	3,4 to 34,5	3 to 12	0,2 to 0,8	2500	172,4	10
705	200 to 1000	13,8 to 68,9	5 to 25	0,3 to 1,7	2500	172,4	25

\*\*Proof Pressure: The maximum pressure to which a pressure sensor may be occasionally subjected, which causes no permanent damage. The unit may require calibration (e.g. start-up, testing)

†Not available on type H122



# 120 Series

## 120 Series

### PRESSURE MODEL CHART

- **Type H122P\***, two hermetically sealed single switches with external adjustment via reference dial, single conduit

Model	Adjustable Set Point Range		Deadband		Proof Pressure**		Dial Divisions
	Low end of range on fall; High end of range on rise		psi	mbar	psi	bar	psi
	psi (unless noted)	bar (unless noted)	psi (unless noted)	mbar (unless noted)	psi	bar	psi (unless noted)
Welded 316L stainless steel bellows and 1/2" NPT (female) pressure connection							
S126B	30 "Hg Vac to 0 psi	-1 to 0	0.7 to 4 "Hg	23,7 to 135,4	5	0,3	0.5 "Hg
S134B	30 "Hg Vac to 20 psi	-1 to 1,4	1 to 6 "Hg	33,9 to 203,2	25	1,7	1 "Hg & 0.5 psi
S144B	0 to 20	0 to 1,4	0.3 to 3	20,7 to 206,8	25	1,7	0.5
S146B	0 to 30	0 to 2,1	0.4 to 4	27,6 to 275,8	40	2,8	0.5
S156B	0 to 100	0 to 6,9	0.6 to 6	40,4 to 413,7	125	8,6	2
S164B	0 to 200	0 to 13,8	1.5 to 13	0,1 to 0,9 bar	200	13,8	5
Brass bellows with nickel-plated brass 1/4" NPT (female) pressure connection; models 126 & 134 have a zinc-plated steel spring which is exposed to media							
126	30 "Hg Vac to 0 psi	-1 to 0	0.7 to 4 "Hg	23,7 to 135,4	5	0,3	0.5 "Hg
134	30 "Hg Vac to 20 psi	-1 to 1,4	1 to 6 "Hg	33,9 to 203,2	25	1,7	1 "Hg & 0.5 psi
144	0 to 20	0 to 1,4	0.3 to 3	20,7 to 206,8	25	1,7	0.5
146	0 to 30	0 to 2,1	0.4 to 4	27,6 to 275,8	40	2,8	0.5
156	0 to 100	0 to 6,9	0.6 to 6	40,4 to 413,7	125	8,6	2
164	0 to 200	0 to 13,8	1.5 to 13	0,1 to 0,9 bar	200	13,8	5
Phosphor bronze bellows with nickel-plated brass 1/4" NPT (female) pressure connection							
270	0 to 200	0 to 13,8	6 to 30	0,4 to 2,1 bar	250	17,2	5
274	0 to 300	0 to 20,7	8 to 40	0,6 to 2,8 bar	350	24,1	10
316L stainless steel bellows and 1/4" NPT (female) pressure connection							
358	0 to 200	0 to 13,8	6 to 30	0,4 to 2,1 bar	250	17,2	5
361	0 to 300	0 to 20,7	8 to 40	0,6 to 2,8 bar	350	24,1	10
376	0 to 500	0 to 34,5	10 to 60	0,7 to 4,1 bar	575	39,6	10
Buna N diaphragm and O-Ring with aluminum 1/4" NPT (female) pressure connection and cap							
450	30 "Hg Vac to 0 psi	-1 to 0	0.4 to 3 "Hg	13,5 to 101,6	225	15,5	0.5 "Hg
452	30 "Hg Vac to 20 psi	-1 to 1,4	0.8 to 6 "Hg	27,1 to 203,2	225	15,5	1 "Hg & 0.5 psi
453	0 to 20	0 to 1,4	0.2 to 2	13,8 to 137,9	225	15,5	0.5
454	0 to 30	0 to 2,1	0.3 to 3	20,7 to 206,8	225	15,5	0.5
Teflon® diaphragm and O-Ring with stainless steel 1/4" NPT (female) 316 pressure connection and cap							
550	30 "Hg Vac to 0 psi	-1 to 0,	0.4 to 3 "Hg	13,5 to 101,6	225	15,5	0.5 "Hg
552	30 "Hg Vac to 20 psi	-1 to 1,4	0.8 to 6 "Hg	27,1 to 203,2	225	15,5	1 "Hg & 0.5 psi
553	0 to 20	0 to 1,4	0.2 to 2	13,8 to 137,9	225	15,5	0.5
554	0 to 30	0 to 2,1	0.3 to 3	20,7 to 206,8	225	15,5	0.5
555	0 to 100	0 to 6,9	0.7 to 7	48,3 to 482,6	225	15,5	2
303 stainless steel piston with Buna N O-Ring and 303 stainless steel 1/4" NPT (female) pressure connection (not recommended for gas service since drying of the O-Ring seal can allow bleeding of medium into the atmosphere)							
612	200 to 3000	13,8 to 206,8	150 to 450	10,3 to 31 bar	10,000	689,5	50
614	500 to 6000	34,5 to 413,7	200 to 500	13,8 to 34,5 bar	10,000	689,5	100

\* **Please note:** Must specify option code 1180 with all models (i.e. H122P-270-1180)

## DIFFERENTIAL PRESSURE MODEL CHART

## • Type J120K, single switch with internal adjustment, dual conduits

Model	Adjustable Set Point Range Low end of range on fall; High end of range on rise		Deadband		Working Pressure***		Proof Pressure**	
	psid (unless noted)	bar (unless noted)	psi (unless noted)	bar (unless noted)	psi (unless noted)	bar	psi	bar
Welded 316L stainless steel bellows and 1/2" NPT (female) pressure connections								
S147B	3 to 30	0,2 to 2,1	0.3 to 1.5	20,7 to 103,4 mbar	30 "Hg Vac to 100	-1 to 6,9	300	20,7
S157B	10 to 100	0,7 to 6,9	0.5 to 2	34,5 to 137,9 mbar	30 "Hg Vac to 180	-1 to 12,4	300	20,7
Welded brass bellows with nickel-plated brass 1/4" NPT (female) pressure connections								
147	3 to 30	0,2 to 2,1	0.3 to 1.5	20,7 to 103,4 mbar	30 "Hg Vac to 100	-1 to 6,9	180	12,4
157	10 to 100	0,7 to 6,9	0.5 to 2	34,5 to 137,9 mbar	30 "Hg Vac to 150	-1 to 10,3	180	12,4
Welded 316L stainless steel bellows and 1/4" NPT (female) pressure connections								
367	10 to 100	0,7 to 6,9	4 to 10	0,3 to 0,7	0 to 350	0 to 24,1	500	34,5
Buna N diaphragm and O-Ring with 303 stainless steel 1/4" NPT (female) pressure connections								
36	3 to 30	0,2 to 2,1	1 to 5	0,1 to 0,3	0 to 350	0 to 24,1	1000	68,9
37	10 to 100	0,7 to 6,9	2 to 8	0,1 to 0,6	0 to 500	0 to 34,5	1000	68,9
38	30 to 300	2,1 to 20,7	2 to 15	0,1 to 1,0	0 to 1000	0 to 68,9	2500	172,4
39	50 to 500	3,4 to 34,5	3 to 20	0,2 to 1,4	0 to 1000	0 to 68,9	2500	172,4
Buna N diaphragm and O-Ring with aluminum 1/4" NPT (female) pressure connections								
455	5 to 80 "wcd	12,4 to 199,1 mbar	1 to 4 "wc	2,5 to 10 mbar	30 "Hg Vac to 225	-1 to 15,5	225	15,5
456	2 to 20	0,1 to 1,4	0.1 to 0.3	6,9 to 20,7 mbar	30 "Hg Vac to 225	-1 to 15,5	225	15,5
457	3 to 30	0,2 to 2,1	0.1 to 0.4	6,9 to 27,6 mbar	30 "Hg Vac to 225	-1 to 15,5	225	15,5
Teflon® and Buna N diaphragms, Buna N O-Ring with aluminum 1/4" NPT (female) pressure connections								
559	10 to 100	0,7 to 6,9	0.2 to 1	13,8 to 68,9 mbar	30 "Hg Vac to 225	-1 to 15,5	225	15,5
Kapton® diaphragms, Buna N sealing diaphragms with aluminum 1/8" NPT (female) pressure connections								
540	0.2 to 7 "wcd	0,5 to 17,4 mbar	0.05 to 0,6 "wc	0,1 to 1,5 mbar	30 "Hg to 200	-1 to 13,8	400	27,6
541	1 to 20 "wcd	2,5 to 49,8 mbar	0.1 to 1.0 "wc	0.2 to 2,5 mbar	30 "Hg to 200	-1 to 13,8	400	27,6
542	5 to 50 "wcd	12,4 to 124,5 mbar	0.2 to 2.5 "wc	0,5 to 6,2 mbar	30 "Hg to 200	-1 to 13,8	400	27,6
543	10 to 200 "wcd	24,9 to 497,8 mbar	0.5 to 8 "wc	1,2 to 19,9 mbar	30 "Hg to 200	-1 to 13,8	400	27,6
544	2 to 20	0,1 to 1,4	0.1 to 1.3	6,9 to 89,6 mbar	30 "Hg to 1200	-1 to 82,7	2500	172,4
545	5 to 50	0,3 to 3,4	0.2 to 2.2	13,8 mbar to 0,1 bar	30 "Hg to 1200	-1 to 82,7	2500	172,4
546	10 to 125	0,7 to 8,6	0.4 to 5.0	27,6 mbar to 0,3 bar	30 "Hg to 1200	-1 to 82,7	2500	172,4
547	50 to 250	3,4 to 17,2	0.8 to 10	0,1 to 0,7	30 "Hg to 1200	-1 to 82,7	2500	172,4
548	100 to 500	6,9 to 34,5	2.0 to 15	0,1 to 1,0	30 "Hg to 1200	-1 to 82,7	2500	172,4

Kapton® is a registered trademark of E.I. DuPont

\*\*Proof Pressure: The maximum pressure to which a pressure sensor may be occasionally subjected, which causes no permanent damage. The unit may require calibration (e.g. start-up, testing)

\*\*\*Working Pressure Range: The pressure range within which two opposing sensors can be safely operated and still maintain set point adjustability.

## DIFFERENTIAL PRESSURE MODEL CHART

- **Type H121K, single switch with external adjustment dial via reference dial, single conduit**
- **Type H122K, dual switch with external adjustment dial via reference dial, single conduit**

Model	Adjustable Set Point Range		Deadband		Working Pressure***		Proof Pressure**		Dial Divisions
	Low end of range on fall; High end of range on rise								
	psid	bar	psi	mbar	psi (unless noted)	bar	psi	bar	psi
Welded 316L stainless steel bellows and 1/2" NPT (female) pressure connections									
S147B	3 to 30	0,2 to 2,1	0.3 to 2	20,7 to 137,9	30 "Hg Vac to 100	-1 to 6,9	300	20,7	0.5
S157B	10 to 100	0,7 to 6,9	0.5 to 3	34,5 to 206,8	30 "Hg Vac to 180	-1 to 12,4	300	20,7	2
Brass bellows with nickel-plated brass 1/4" NPT (female) pressure connections									
147	3 to 30	0,2 to 2,1	0.3 to 2	20,7 to 137,9	30 "Hg Vac to 100	-1 to 6,9	180	12,4	0.5
157	10 to 100	0,7 to 6,9	0.5 to 3	34,5 to 206,8	30 "Hg Vac to 150	-1 to 10,3	180	12,4	2
Buna N diaphragm, O-Ring with aluminum 1/4" NPT (female) pressure connections									
456	2 to 20	0,1 to 1,4	0.1 to 0.3	6,9 to 20,7	30 "Hg Vac to 225	-1 to 15,5	225	15,5	0.5
457	3 to 30	0,2 to 2,1	0.1 to 0.4	6,9 to 27,6	30 "Hg Vac to 225	-1 to 15,5	225	15,5	0.5
Teflon® and Buna N diaphragms, Buna N O-Ring with aluminum 1/4" NPT (female) pressure connections									
559	10 to 100	0,7 to 6,9	0.2 to 1	13,8 to 68,9	30 "Hg Vac to 225	-1 to 15,5	225	15,5	2

**\*\*Proof Pressure:** The maximum pressure to which a pressure sensor may be occasionally subjected, which causes no permanent damage. The unit may require calibration (e.g. start-up, testing)

**\*\*\*Working Pressure Range:** The pressure range within which two opposing sensors can be safely operated and still maintain set point adjustability.



Differential Pressure Indicating Option M210

## TEMPERATURE MODEL CHART

- **Type B121, B121-13272 (HTFP), single switch, immersion stem, external adjustment via reference dial, single conduit**
- **Type B122, B122-13322 (HTFP), dual switch, immersion stem, external adjustment via reference dial, single conduit**
- **Type C120, single switch, immersion stem, internal adjustment, dual conduits**
- **Type E121, E121-13273 (HTFP), single switch, bulb and capillary, external adjustment via reference dial, single conduit**
- **Type E122, E122-13321 (HTFP), dual switch, bulb and capillary, external adjustment via reference dial, single conduit**
- **Type F120, single switch, bulb and capillary, internal adjustment, dual conduits**

Model	Adjustable Set Point Range		Max. Temp.		Scale Div.		Stem or Bulb Size* / Finish**
	°F	°C	°F	°C	°F	°C	
Type B121, B121-13272 (HTFP), single switch, immersion stem, external adjustment via reference dial. Type B122, B122-13322 (HTFP), dual switch, immersion stem, external adjustment via reference dial. Type C120, single switch, immersion stem, internal adjustment							
120	0 to 225	-17.8 to 107.2	275	135	5†	5†	9/16" x 1-7/8" below thread, 1/2" NPT nickel-plated brass
121	200 to 425	93.3 to 218.3	475	246.1	5†	5†	9/16" x 1-7/8" below thread, 1/2" NPT nickel-plated brass
HTFP (Freeze Protection)	15 to 140	-9.4 to 60	160	71.1	2†	2†	9/16" x 2-11/16" long stainless steel
Type E121, E121-13273 (HTFP), single switch, bulb and capillary, external adjustment via reference dial. Type E122, E122-13321 (HTFP), dual switch, bulb and capillary, external adjustment via reference dial							
2BSA	-120 to 100	-84.4 to 37.8	150	65.6	5	5	3/8 x 2-7/16"
2BSB	30 to 250	-1.1 to 121.1	300	148.9	5	5	3/8 x 2-7/16"
3BS	100 to 400	37.8 to 204.4	450	232.2	5	5	3/8 x 2-1/8"
4BS	25 to 100	-3.9 to 37.8	150	65.6	2	1	3/8 x 6-3/4"
5BS	-20 to 80	-28.9 to 26.7	130	54.4	2	2	3/8 x 5"
8BS	350 to 640	176.7 to 337.8	690	365.6	5	5	3/8 x 3-1/4"
HTFP (Heat Tracing)	25 to 325	-3.9 to 162.8	360	182.2	5	5	1/4" x 10-1/4"
Type F120, single switch, bulb and capillary, internal adjustment							
1BS	-180 to 120	-117.8 to 48.9	170	76.7	N/A		3/8 x 3-3/4"
2BS	-125 to 350	-87.2 to 176.7	400	204.4	N/A		3/8 x 2-7/16"
3BS	-125 to 500	-87.2 to 260	550	287.8	N/A		3/8 x 2-1/8"
4BS	-40 to 120	-40 to 48.9	170	76.7	N/A		3/8 x 6-3/4"
5BS	-40 to 180	-40 to 82.2	230	110	N/A		3/8 x 5"
6BS	0 to 250	-17.8 to 121.1	300	148.9	N/A		3/8 x 4-1/2"
7BS	0 to 400	-17.8 to 204.4	450	232.2	N/A		3/8 x 3"
8BS	50 to 650	10 to 343.3	700	371.1	N/A		3/8 x 3-1/4"

† Types B121, B122 only.

**\*Optional immersion** stem lengths and capillary lengths are available. Standard capillary length is 6 FT except HTFP models which are 10 FT.

**\*\*Optional** stainless steel **immersion** stem, and **armored capillary** covering available.



## INDICATING TEMPERATURE CONTROL MODEL CHART

- Type 820E, single switch, external adjustment and temperature indication, dual conduits
- Type 822E, dual switch, external adjustment and temperature indication, dual conduits

Model	Adjustable Set Point Range		Max. Temp.		Scale Div.		Bulb Size
	°F	°C	°F	°C	°F	°C	OD x Length
1BS	-180 to 120	-117.8 to 48.9	170	76.7	5	5	3/8 x 3-3/4"
2BS	-125 to 350	-87.2 to 176.7	400	204.4	10	5	3/8 x 2-7/16"
3BS	-125 to 500	-87.2 to 260	550	287.8	10	5	3/8 x 2-1/8"
4BS	-40 to 120	-40 to 48.9	170	76.7	5	2	3/8 x 6-3/4"
5BS	-40 to 180	-40 to 82.2	230	110	5	2	3/8 x 5"
6BS	0 to 250	-17.8 to 121.1	300	148.9	5	2	3/8 x 4-1/2"
7BS	0 to 400	-17.8 to 204.4	450	232.2	10	5	3/8 x 3"
8BS	50 to 650	10 to 343.3	700	371.1	10	10	3/8 x 3-1/4"

*Standard capillary length is 6ft. optional lengths and capillary protection available*



## HOW TO ORDER

### BUILDING A PART NUMBER

#### Select a **Type**

Refer to the "Type" section below.  
Determine type number based on switch output, enclosure, adjustment and reference.  
Fill in the type portion of your part number with the corresponding number.

#### Select a **Model**

Refer to the "Model Charts"  
Determine model based on adjustable range, deadband and proof pressure.  
Fill in the model portion of your part number with the corresponding number.

#### Select an **Option**

Refer to the "Options" section  
Determine option number based on switch output, optional materials or other product enhancements.  
Fill in the option portion of your part number with the corresponding number.  
Leave "option" portion blank if no options are needed. FOR MULTIPLE OPTIONS: Call United Electric Controls.

TYPE	DESCRIPTION
Pressure	Type J120 - <b>One</b> SPDT; epoxy coated enclosure; <b>internal</b> adjustment with <b>no reference scale, dual</b> conduits Type H121 - <b>One</b> SPDT; epoxy coated enclosure; <b>external</b> adjustment <b>with reference dial, single</b> conduit Type H122 - <b>Two</b> SPDT; epoxy coated enclosure; <b>external</b> adjustment <b>with reference dial, single</b> conduit Type H122P - <b>Two</b> SPDT; <b>hermetically</b> sealed switches; epoxy coated enclosure; <b>external</b> adjustment <b>with reference dial, single</b> conduit
Differential Pressure	Type J120K - <b>One</b> SPDT; epoxy coated enclosure; <b>internal</b> adjustment with <b>no reference scale, dual</b> conduits Type H121K - <b>One</b> SPDT; epoxy coated enclosure; <b>external</b> adjustment <b>with reference dial, single</b> conduit Type H122K - <b>Two</b> SPDT; epoxy coated enclosure; <b>external</b> adjustment <b>with reference dial, single</b> conduit
Temperature	Type B121 - Immersion stem; <b>one</b> SPDT; epoxy coated enclosure; <b>external</b> adjustment <b>with reference dial, single</b> conduit Type B122 - Immersion stem; <b>two</b> SPDT; epoxy coated enclosure; <b>external</b> adjustment <b>with reference dial, single</b> conduit Type C120 - Immersion stem; <b>one</b> SPDT; epoxy coated enclosure; <b>internal</b> adjustment with <b>no reference scale, dual</b> conduits Type E121 - Bulb and capillary; <b>one</b> SPDT; epoxy coated enclosure; <b>external</b> adjustment <b>with reference dial, single</b> conduit Type E122 - Bulb and capillary; <b>two</b> SPDT; epoxy coated enclosure; <b>external</b> adjustment <b>with reference dial, single</b> conduit Type F120 - Bulb and capillary; <b>one</b> SPDT; epoxy coated enclosure; <b>internal</b> adjustment with <b>no reference dial, dual</b> conduits Type 820E - Bulb and capillary; <b>one</b> SPDT; <b>external</b> adjustment and temperature <b>indication, dual</b> conduits Type 822E - Bulb and capillary; <b>two</b> SPDT; <b>external</b> adjustment and temperature <b>indication, dual</b> conduits

### SWITCH OPTIONS\*\*

0140	Gold contacts, 1 amp 125 VAC resistive, NOT AVAILABLE TYPE H122P, 820E, & 822E
0500	Close deadband, 5 amp 125/250 VAC resistive. NOT AVAILABLE TYPE H122P MODELS 520-535
1010	DPDT switch, 10 amp 125/250 VAC resistive. NOT AVAILABLE TEMPERATURE VERSIONS; TYPES H122, H122P, H122K; OR J120K MODELS 36-39, 367, AND 540-548; OR J120 MODELS 171-194, 483-494, 520-535, 560-567, 680
1070	10 amp 125 VDC or VAC resistive; deadband and minimum set point will increase. NOT AVAILABLE TYPES 820E, 822E, H122P, H122K, B122, AND J120K MODELS 36-39; J120 MODELS 171-194, 483-494, 520-535, 560-567
1180	Hermetically sealed, SPDT, 11 amp 125/250 VAC resistive, must be specified with type H122P. NOT AVAILABLE TYPES B122, E122, H122, H121K and H122K, 820 AND 822E; deadband and minimum set point will increase.
1190	Hermetically sealed, DPDT, 11 amp 125/250 VAC; products set on rising pressure or temperature due to inherent separation of circuits on falling pressure or temperature; specify option 1195 if setting on fall is required; deadband and minimum set point will increase. NOT AVAILABLE TYPES 820E, 822E, B122, E122, H122, H121K, H122K, H122P or models 523, 533
1195	Hermetically sealed, DPDT, 11 amp 125/250 VAC; products set on falling pressure or temperature due to inherent separation of circuits on rising pressure or temperature; specify option 1190 if setting on rise is required; deadband and minimum set point will increase. NOT AVAILABLE TYPES 820E, 822E, B122, E122, H122, H121K, H122K, H122P or models 523, 533

\*\* All switches have limited DC capabilities. Consult factory for details.



# 120 Series

## 120 Series

### SWITCH OPTIONS\*\* (CONT.)

1519*	Adjustable deadband, 15 amp 125/250/480 VAC resistive; adjustable wheel changes rise setting only; if adjustment of fall setting is required use primary adjustment; deadband and minimum set point will increase. NOT AVAILABLE TYPES 820E, 822E, B121, B122, E121, E122, H121, H122, H121K, H122K, H122P or models 171-194, 483-494, 520-535, 560-567, 612-616
1530	External manual reset, 15 amp 125/250/480 VAC resistive; latches on rise only. NOT AVAILABLE TYPES 820E, 822E, B122, E122, H122, H121K, H122K, H122P
1535	High ambient, 15 amp 125/250 VAC resistive; temperatures up to 250°F (120°C). NOT AVAILABLE TYPES 820E, 822E, H122P models 520-535
1537	Vapor sealed switch, 15 amp 125/250 VAC resistive. NOT AVAILABLE TYPES 820E, 822E, H122P or models 520-535
1539	Fungus resistant case, 15 amp 125/250 VAC resistive. NOT AVAILABLE TYPES 820E, 822E, H122P or models 520-535
2000	20 amp 125/250 VAC resistive. NOT AVAILABLE MODELS H122P, 520-535, 540-548
3000	30 amp 125/250/277 VAC resistive. NOT AVAILABLE TYPES 820E, 822E, B121, B122, E122, H121, H122, H121K, H122K, H122P, J120K or models 171-194, 483-494, 520-535, 540-548, 560-567

### SENSOR OPTIONS

M504	316L stainless steel stem. AVAILABLE TEMPERATURE MODELS 120 AND 121 ONLY
M540	Viton® construction; (deadbands and low end of range may increase slightly) wetted parts include Viton® diaphragm and O-Ring. AVAILABLE MODELS 36-39, 450-457, 540-548 (Kapton® diaphragm, Viton® O-ring and sealing diaphragms), 612-616 (O-Ring only) with standard pressure connection. AVAILABLE TYPE J120 MODELS 701-705 and TYPES H121 and H122 MODELS 701-703 with stainless steel pressure connection.
M913	1/4" NPT (female) stainless steel pressure connection. AVAILABLE ON MODELS S126B - S146B, S152B, S156B, AND S164B ONLY
M914	1/2" NPT (female) stainless steel pressure connection. AVAILABLE ON MODELS 356, 358, 361, AND 376 ONLY

### OPTIONAL SENSOR MATERIAL FOR "WC RANGES. AVAILABLE MODELS 520-525

XC001	Aluminum pressure connection, Viton® diaphragm, Viton® O-Ring
XC002	Aluminum pressure connection, Kapton® diaphragm, Buna N O-Ring
XC003	Aluminum pressure connection, Kapton® diaphragm, Viton® O-Ring
XC004	316L Stainless steel pressure connection, 316L Stainless steel diaphragm, Viton® O-Ring (Over range pressure is limited to 100 psi)
XC005	316L Stainless steel pressure connection, Viton® diaphragm, Viton® O-Ring
XC006	316L Stainless steel pressure connection, Kapton® diaphragm, Viton® O-Ring
XC007	316L Stainless steel pressure connection, Teflon® diaphragm, Viton® O-Ring

### OPTIONAL SENSOR MATERIAL FOR CORROSIVE MEDIA. AVAILABLE MODELS 183-189, 483-489

XD002	Hastelloy® C diaphragm (NACE MR-0175 compliant)
XD003	Monel® diaphragm (NACE MR-0175 compliant)
XP112	Hastelloy® C pressure connection (NACE MR-0175 compliant)
XP113	Monel® pressure connection (NACE MR-0175 compliant)

\*Please note: In order to accommodate free movement of adjustable wheel, left hand electrical conduit is permanently sealed.

\*\* All switches have limited DC capabilities. Consult factory for details.

**OPTIONAL SENSOR MATERIAL FOR CORROSIVE MEDIA (CONT.)**

XR211	Kalrez® O-Ring
XR212	Silicone O-Ring. NOT AVAILABLE MODELS 188-189, 488-489
XR213	Ethylene propylene O-Ring
XR214	Aflas® O-Ring

**OTHER OPTIONS**

M201	Factory set one switch
M202	Factory set two switches. NOT AVAILABLE SINGLE SWITCH VERSIONS
M210	Differential pressure indication. AVAILABLE ON H121K, H122K, MODELS 147, 157, S147B, S157B ONLY
M277	Range indicated on nameplate in kPa or MPa. NOT AVAILABLE ON TEMPERATURE VERSIONS
M278	Range indicated on nameplate in Kg/cm <sup>2</sup> . NOT AVAILABLE ON TEMPERATURE VERSIONS
M320	Tamper resistant cover for indication portion of control, internal adjustment. AVAILABLE TYPES 820E & 822E ONLY
M403	Flameproof compliance for Australia per IECEx standards
M404	Flameproof compliance for Ukraine per Gosnadzorohrantruda standards
M405	Intrinsic safety compliance for European Union per ATEX standards. NOT AVAILABLE TYPES 820E & 822E
M406	Flameproof and intrinsic safety compliance for Russia per Gosgortekhnadzor standards. Intrinsic safety NOT AVAILABLE TYPES 820E & 822E
M407	CE Compliance to Pressure Equipment Directive (category IV). AVAILABLE ON MODELS 171-174, 183-189, 190-194, AND 701-705 ONLY. Optional sensor material for corrosive media are excluded
M408	Flameproof compliance for China per CQST standards
M440	Cover chain
M444	Paper ID tag
M446	Stainless steel ID tag & wire attachment
M450	Breather drain. NOT AVAILABLE WITH OPTIONS 1530, M210 OR WITH ATEX CERTIFICATION
M550	Oxygen service cleaning; internal construction may change
6361-704	Surface and pipe mounting hardware. (required for models 520-535, 540-548 when surface mounting)

**ALSO AVAILABLE:** 150# and 300# flanges (consult factory for part numbers)

**NOTE:** Options available on models 13272, 13273, 13321, 13322, 15622, and 15834-15839 are M201, M202, M444, M446 and various certification related documentation.



## OPTIONS FOR TEMPERATURE MODELS

### UNION CONNECTORS

Option	Replacement Number	Description
<u>Brass</u>		
W027	SD6213-27	1/2" NPT w/ 3/4" bushing
W045	SD6213-45	3/4" NPT
W051	SD6213-51	1/2" NPT
<u>304 Stainless Steel</u>		
W028	SD6213-28	1/2" NPT w/ 3/4" bushing
W046	SD6213-46	3/4" NPT
W050	SD6213-50	1/2" NPT

### THERMOWELLS

*For all bulb & capillary switches, except Models 13273 and 13321*

<u>Brass</u>		
W075	SD6225-75	3/4" NPT bushing adapter, 4" BT
W191	SD6225-191	1/2" NPT, 4" BT
W118	SD6225-118	3/4" NPT bushing adapter, 7" BT
W192	SD6225-192	1/2" NPT, 7" BT
<u>316 Stainless Steel</u>		
W076	SD6225-76	3/4" NPT, 4.5" BT
W193	SD6225-193	1/2" NPT, 4.5" BT
W119	SD6225-119	3/4" NPT, 7.5" BT
W177	SD6225-177	1/2" NPT, 7.5" BT

*For all immersion stem switches, except Models 13272 and 13322*

W139	SD6225-139	3/4" NPT X 1-23/32" BT, BRASS
W140	SD6225-140	3/4" NPT X 1-23/32" BT, 316 ST/ST

### W000 IMMERSION STEM AND THERMOWELLS

Note: Option W000 is a special Immersion Stem construction that has no external thread. This option fits inside a special thermowell and is secured with a set-screw.

Option	Description
W000	Immersion stem only, BRASS
W097	Immersion stem and thermowell. Includes W000 stem and 1/2" NPT x 1-23/32" BT BRASS thermowell
W099	Immersion stem and thermowell. Includes W000 stem and 1/2" NPT x 1-23/32" BT 316 ST/ST thermowell

### OPTIONAL LENGTHS

Optional immersion stem lengths to 15" available in brass, with or without 316 ST/ST thermowell. Consult UE for additional information.

Optional capillary length to \*50' available in copper or 304 ST/ST. Armor or Teflon® capillary protection available to lengths less than or equal to capillary length. Consult UE for additional information.

\*Consult UE regarding repeatability and ambient effects on capillary lengths over 30'.

## DIMENSIONAL DRAWINGS

(Dimensional drawings for all models may be found at [www.ueonline.com](http://www.ueonline.com))

### Internal Set Point Adjustment, dual conduits

Types J120, J120K, C120, F120

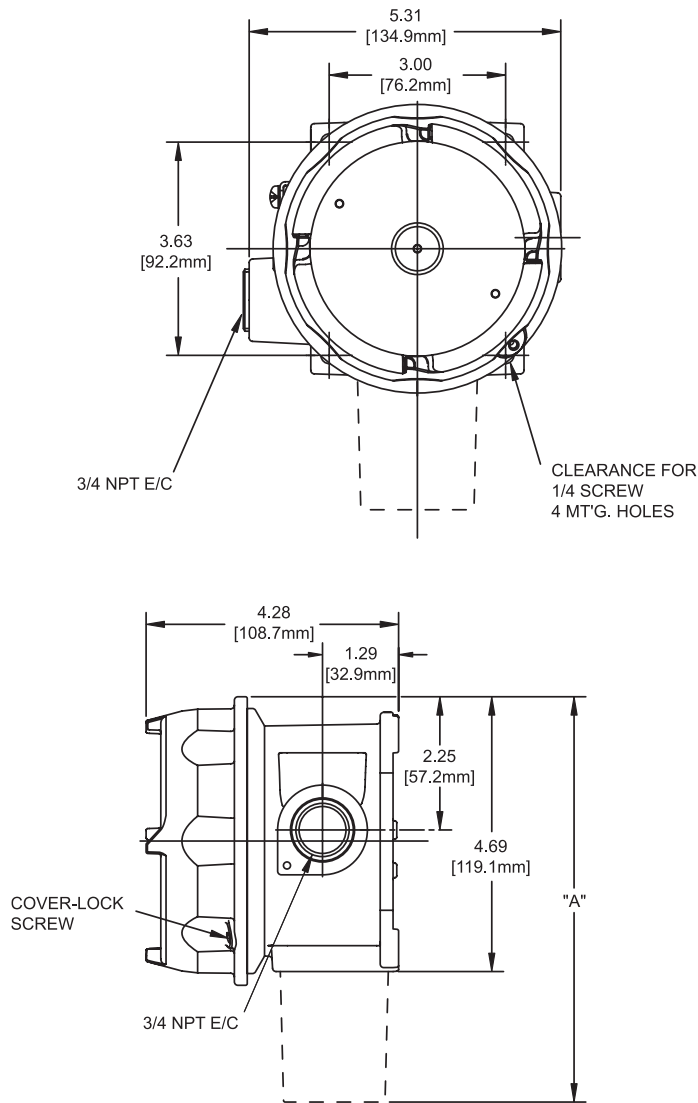

All dimensions stated in inches (millimeters)

Models	Dimension A		NPT
	Inches	mm	
<b>Pressure</b>			
126-164	7.25	184.2	1/4
S126B-S164B	7.63	193.8	1/2
171-174	8.72	221.5	1/2
183-186, 483-486	8.41	213.6	1/2
188-189, 488-489	7.47	189.7	1/2
190-194, 490-494	7.44	189.0	1/2
270-274	8.13	206.5	1/4
356-361, 376	8.09	205.5	1/4
450, 452	8.81	223.8	1/4
451, 453, 454	8.06	204.7	1/4
520-525	9.25	235.0	1/2
530-535	8.84	224.5	1/2
550, 552	8.81	223.8	1/4
551, 553-555	8.34	211.8	1/4
560-564	7.53	191.3	2" Sanitary
565-567	7.53	191.3	1-1/2" Sanitary
612, 616	7.88	200.2	1/4
680	8.13	206.5	1/4
701-705, 15622	7.44	189.0	1/4
<b>Differential Pressure</b>			
36-39, 147-157, 367	7.59	192.8	1/4
S147B-S157B	7.59	192.8	1/2
455-457, 559	8.44	214.4	1/4
540-543	9.34	237.2	1/8
544-548	9.41	239.0	1/8
<b>Temperature</b>			
120-121	9.13	231.9	Immersion Stem
1B5-8B5	8.47	215.1	Bulb & capillary

## DIMENSIONAL DRAWINGS

(Dimensional drawings for all models may be found at [www.ueonline.com](http://www.ueonline.com))

### External Set Point Adjustment, single conduit

Types B121, B122, E121,  
E122, H121, H122,  
H122P, H121K, H122K

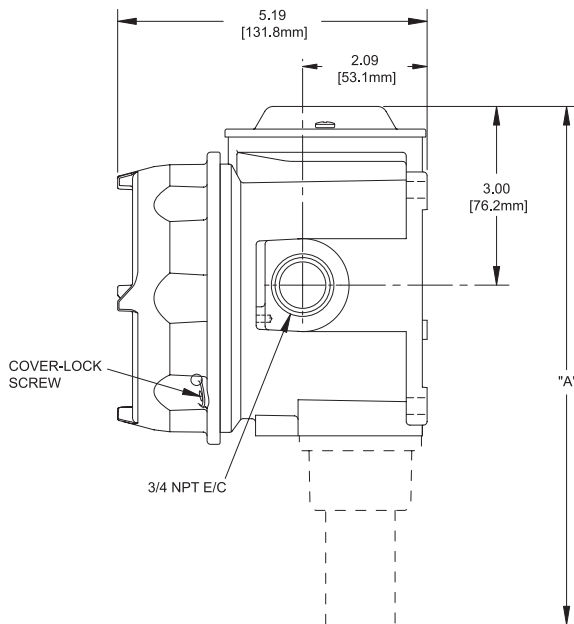
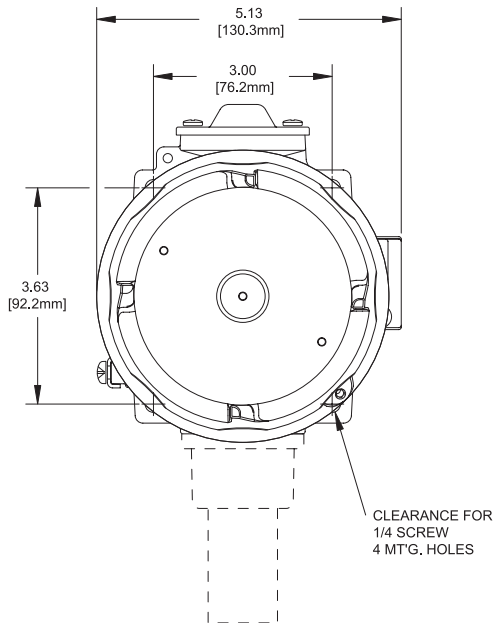

Models	Dimension A		NPT
	Inches	mm	
<b>Pressure</b>			
126-164	8.09	205.5	1/4
5126B-5164B	8.50	215.9	1/2
270-274	7.88	200.2	1/4
358-376	7.81	198.4	1/4
450, 452	9.69	246.1	1/4
453, 454	8.94	227.1	1/4
550, 552	9.75	247.7	1/4
553-555	9.31	236.5	1/4
612, 614	8.75	222.3	1/4
701-705	8.31	211.1	1/4
<b>Differential Pressure</b>			
147-157	8.44	214.4	1/4
5147B-5157B	8.44	214.4	1/2
456-457, 559	9.31	236.5	1/4
<b>Temperature</b>			
120,121	10.00	254.0	Immersion Stem
285-885	9.31	236.5	Bulb & capillary
13272, 13322	10.00	254.0	Immersion Stem (Freeze protection)
13273, 13321	9.31	236.5	Bulb & capillary (Heat tracing)

## DIMENSIONAL DRAWINGS

(Dimensional drawings for all models may be found at [www.ueonline.com](http://www.ueonline.com))

### External Set Point Adjustment & Temperature Indication

Type 820E  
single switch

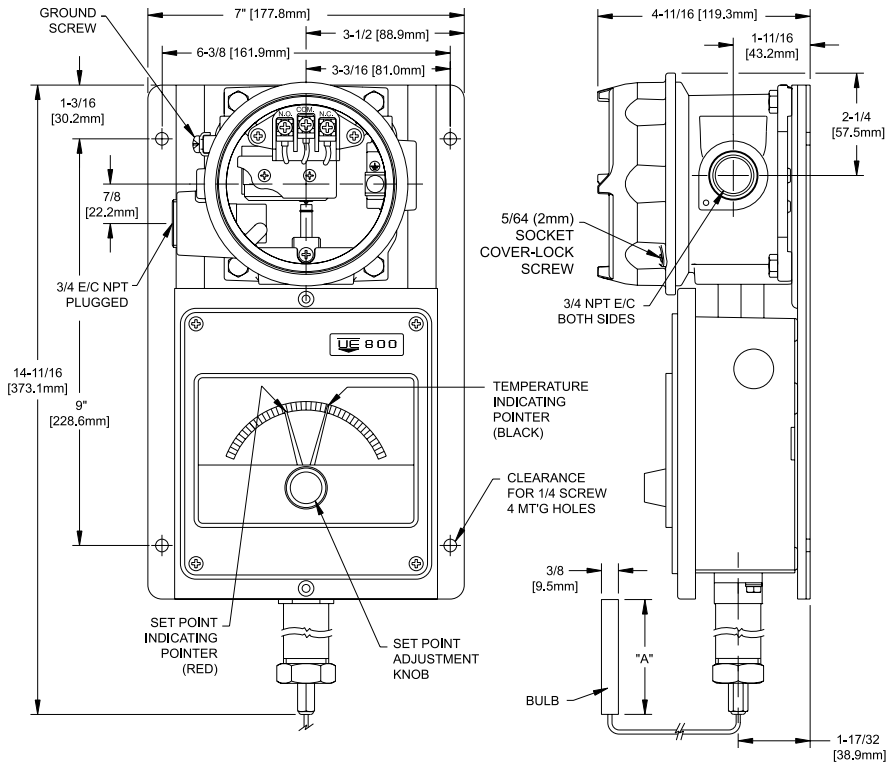

Models	Inches	mm
1BS	3-3/4	95,3
2BS	2-7/16	62,0
3BS	2-1/8	54,0
4BS	6-3/4	171,5
5BS	5	127,0
6BS	4-1/2	114,3
7BS	3	76,2
8BS	3-1/4	82,6

Type 822E  
dual switch

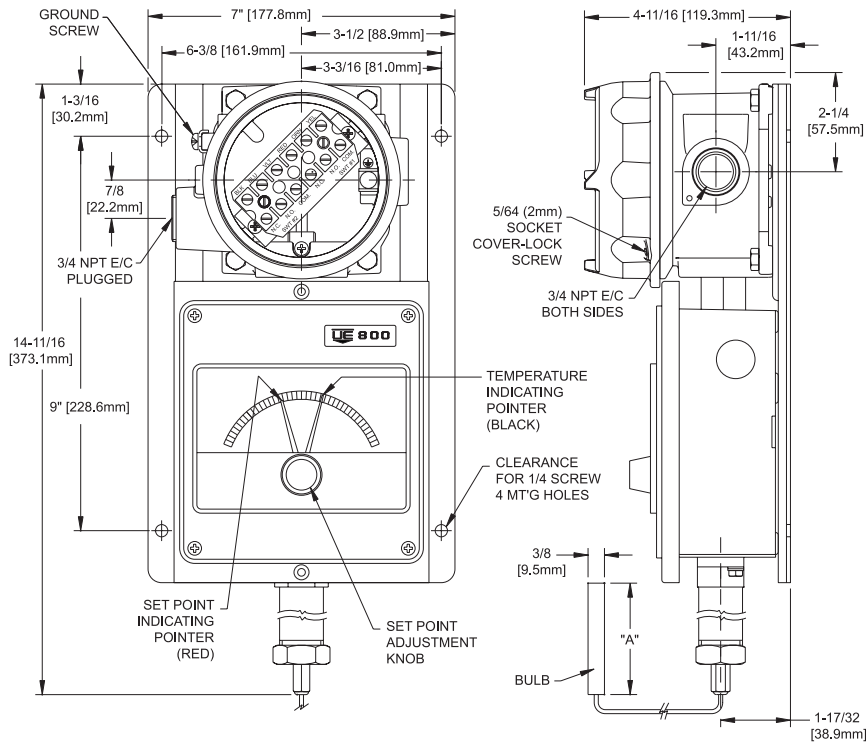

## DIMENSIONAL DRAWINGS

### SENSORS

#### Pressure Sensors

(see drawings and charts on page 21 & 22 for complete dimensions)

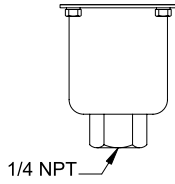

Models 126-164

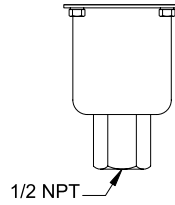

Models S126B-S164B

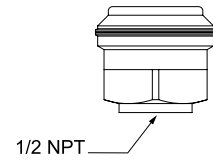

Models 171-174

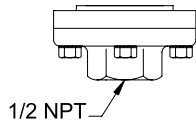

Models 183-186, 483-486

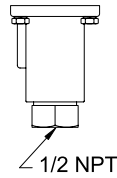

Models 188-194, 488-494

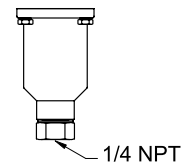

J120 Models 270-376, 680

**DIMENSIONAL DRAWINGS**

**SENSORS**

**Pressure Sensors**

*(see drawings and charts on page 21 & 22 for complete dimensions)*

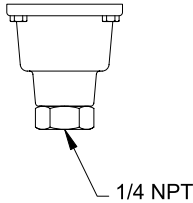

H121/H122 Models 270-376

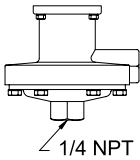

Models 450-454, 550-555

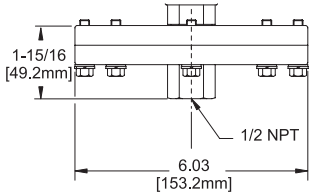

Models 520-525

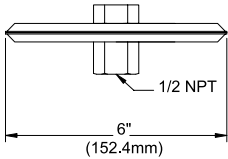

Models 530-535

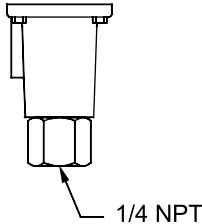

Models 612-616, 701-705, 15622

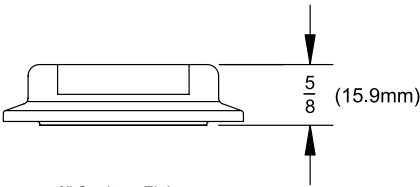

Models 560-564

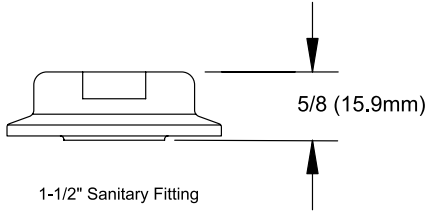

Models 565-567

## DIMENSIONAL DRAWINGS

### SENSORS

#### Differential Pressure Sensors

(see drawings and charts on page 21 & 22 for complete dimensions)

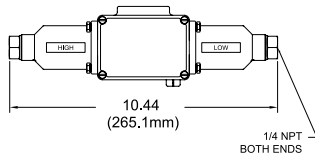

J120K Models 367

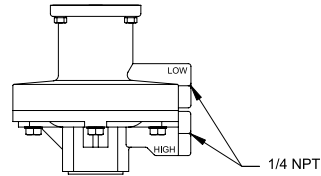

Models 455-457, 559

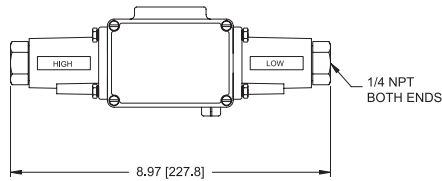

J120K Models 36-39

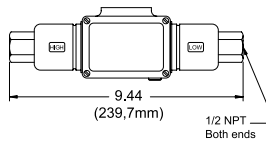

Models S147B-S157B

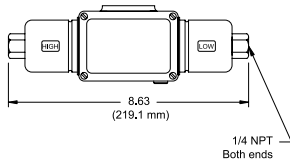

Models 147-157

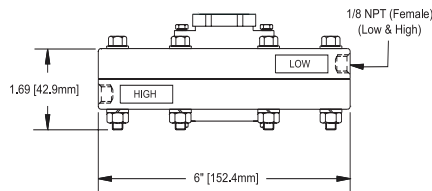

Models 540-543

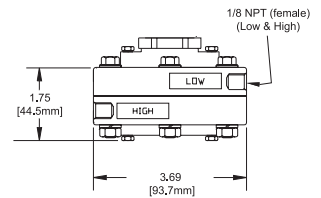

Models 544-548

#### Temperature Sensors

(see drawings and charts on page 18 and 19 for complete dimensions)

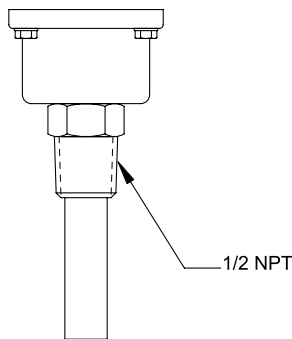

Models 120-121

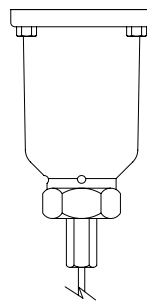

Models 1B5-8B5

## ALTERNATIVE PRODUCTS FROM UE

### Spectra 12 Series

- Compact, cylindrical stainless steel design
- Hermetically sealed switch
- Explosion Proof
- Snap-acting belleville spring mechanism to enhance vibration resistance and set point stability
- Pressure ranges 1 to 6,000 psi;  
DP working pressure ranges 0 to 2500 psid;  
temperature ranges -130 to 650°F



### One Series

- Electronic solid-state reliability
- Two-wire operation
- Digital display with keypad set-up
- 100% of range adjustable on-off deadband
- 4-20 mA output models
- Continuous diagnostic health check



### TX200 Series Pressure Transmitters

- Welded, hermetically sealed, 316 Stainless steel construction
- Ranges 0 to 100 psi up to 0 to 25,000 psi
- Choice of field adjustable or fixed range models
- 4-20 mA or 1-5 VDC output

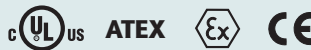

### 117 Series

- Single Switch for Corrosive and Hazardous Division 2 Locations
- Compact pressure, differential pressure and temperature models
- Hermetically-sealed SPDT and DPDT output
- Epoxy-coated weather-tight design houses stainless steel internal construction
- Convenient terminal block wiring



### Temperature Sensors

Rugged RTD's and Thermocouples for process and energy applications, available with Nema 4X and explosion-proof heads to match heat-trace, turbine, combustion, and stack-emission applications



## RECOMMENDED PRACTICES AND WARNINGS

United Electric Controls Company recommends careful consideration of the following factors when specifying and installing UE pressure and temperature units. Before installing a unit, the Installation and Maintenance instructions provided with unit must be read and understood.

- To avoid damaging unit, proof pressure and maximum temperature limits stated in literature and on nameplates must never be exceeded, even by surges in the system. Operation of the unit up to maximum pressure or temperature is acceptable on a limited basis (e.g., start-up, testing) but continuous operation must be restricted to the designated adjustable range. Excessive cycling at maximum pressure or temperature limits could reduce sensor life.
- A back-up unit is necessary for applications where damage to a primary unit could endanger life, limb or property. A high or low limit switch is necessary for applications where a dangerous runaway condition could result.
- The adjustable range must be selected so that incorrect, inadvertent or malicious setting at any range point cannot result in an unsafe system condition.
- Install unit where shock, vibration and ambient temperature fluctuations will not damage unit or affect operation. When applicable, orient unit so that moisture does not enter the enclosure via the electrical connection. When appropriate, this entry point should be sealed to prevent moisture entry.
- Unit must not be altered or modified after shipment. Consult UE if modification is necessary.
- Monitor operation to observe warning signs of possible damage to unit, such as drift in set point or faulty display. Check unit immediately.
- Preventative maintenance and periodic testing is necessary for critical applications where damage could endanger property or personnel.
- Electrical ratings stated in literature and on nameplate must not be exceeded. Overload on a switch can cause damage, even on the first cycle. Wire unit according to local and national electrical codes, using wire size recommended in installation sheet.
- Do not mount unit in ambient temp. exceeding published limits.

## LIMITED WARRANTY

Seller warrants that the product hereby purchased is, upon delivery, free from defects in material and workmanship and that any such product which is found to be defective in such workmanship or material will be repaired or replaced by Seller (Ex-works, Factory, Watertown, Massachusetts. INCOTERMS); provided, however, that this warranty applies only to equipment found to be so defective within a period of 24 months from the date of manufacture by the Seller. Seller shall not be obligated under this warranty for alleged defects which examination discloses are due to tampering, misuse, neglect, improper storage, and in any case where products are disassembled by anyone other than authorized Seller's representatives. EXCEPT FOR THE LIMITED WARRANTY OF REPAIR AND REPLACEMENT STATED ABOVE, SELLER DISCLAIMS ALL WARRANTIES WHATSOEVER WITH RESPECT TO THE PRODUCT, INCLUDING ALL IMPLIED WARRANTIES OF MERCHANTABILITY OR FITNESS FOR ANY PARTICULAR PURPOSE.

## LIMITATION OF SELLER'S LIABILITY

SELLER'S LIABILITY TO BUYER FOR ANY LOSS OR CLAIM, INCLUDING LIABILITY INCURRED IN CONNECTION WITH (I) BREACH OF ANY WARRANTY WHATSOEVER, EXPRESSED OR IMPLIED, (II) A BREACH OF CONTRACT, (III) A NEGLIGENT ACT OR ACTS (OR NEGLIGENT FAILURE TO ACT) COMMITTED BY SELLER, OR (IV) AN ACT FOR WHICH STRICT LIABILITY WILL BE INPUTTED TO SELLER, IS LIMITED TO THE "LIMITED WARRANTY" OF REPAIR AND/OR REPLACEMENT AS SO STATED IN OUR WARRANTY OF PRODUCT. IN NO EVENT SHALL THE SELLER BE LIABLE FOR ANY SPECIAL, INDIRECT, CONSEQUENTIAL OR OTHER DAMAGES OF A LIKE GENERAL NATURE, INCLUDING, WITHOUT LIMITATION, LOSS OF PROFITS OR PRODUCTION, OR LOSS OR EXPENSES OF ANY NATURE INCURRED BY THE BUYER OR ANY THIRD PARTY.

*UE specifications subject to change without notice.*

## U.S. SALES OFFICES

United Electric Controls  
31 Old Stage Road  
Hampton Falls, NH 03844  
Phone: 617-899-1132  
email: [northeastsales@ueonline.com](mailto:northeastsales@ueonline.com)

United Electric Controls  
28 N. Wise Ave.  
Freeport, IL 61032  
Phone: 815-341-2588  
email: [midwestsales@ueonline.com](mailto:midwestsales@ueonline.com)

United Electric Controls  
1022 Vineyard Drive  
Conyers, GA 30013  
Phone: 770-335-9802  
email: [southeastsales@ueonline.com](mailto:southeastsales@ueonline.com)

United Electric Controls  
5829 Grazing Court  
Mason, OH 45040  
Phone: 513-535-5486  
email: [midatlanticsales@ueonline.com](mailto:midatlanticsales@ueonline.com)

United Electric Controls  
102 Salazar Court  
Clayton, CA 94517  
Phone: 925-408-5997  
email: [westcoastsales@ueonline.com](mailto:westcoastsales@ueonline.com)

United Electric Controls  
27 Summit Terrace  
Sparta, NJ 07871  
Phone: 973-271-2550  
email: [easternsales@ueonline.com](mailto:easternsales@ueonline.com)

United Electric Controls  
4306 Whickham Drive  
Fulshear, TX 77441  
Phone: 832-457-6138  
email: [southwestsales@ueonline.com](mailto:southwestsales@ueonline.com)

United Electric Controls  
5201 Arbor Court  
Odessa, TX 79762  
Phone: 432-770-4164  
email: [westtexasales@ueonline.com](mailto:westtexasales@ueonline.com)

## CANADA

EASTERN  
68 Mosley Crescent  
Brampton, Ontario  
Canada L6Y 5C8  
Phone: 905-455-5131  
FAX: 905-455-5131

WESTERN  
148 Silver Ridge Close N.W.  
Calgary, Alberta  
Canada T3B 3T4  
Phone: 403-247-3724  
FAX: 403-247-3724

## INTERNATIONAL OFFICES

CHINA  
United Electric Controls, *Shanghai*  
Room 1011, 10th Flr,  
Huai Hai Zhonghua Building  
No. 885, Renmin Road, Luwan District  
Shanghai 200010, P.R. China  
Phone: +8621-6255 8059  
email: [chinasales@ueonline.com](mailto:chinasales@ueonline.com)

United Electric Controls, *Beijing*  
Room 1006, Jainhao International Bldg.  
Block D, No. 116  
Zizhuyuanlu, Haidian District  
Beijing, China 100089  
Phone & Fax: +86-10-5893-0551  
email: [beijingsales@ueonline.com](mailto:beijingsales@ueonline.com)

EASTERN EUROPE & SCANDINAVIA  
United Electric Controls  
05-806 Komorow  
Kujawska 5, Poland  
Phone: +48 22 499 4804  
email: [easterneuropesales@ueonline.com](mailto:easterneuropesales@ueonline.com)

GERMANY  
United Electric Controls  
An Der Zentlinde 21  
D-64711 Erbach, Germany  
Phone: 496-062-7400  
email: [europesales@ueonline.com](mailto:europesales@ueonline.com)

INDIA  
United Electric Controls  
House no. 7, Kamalkunj Society  
Nizampura,  
Baraoda (Gujarat), India  
Phone: +91 (-265) -2788654  
email: [indiasales@ueonline.com](mailto:indiasales@ueonline.com)

ASIA-PACIFIC  
United Electric Controls, Far East  
No. 1-2-2, 2nd Floor  
Jalan 4/101C  
Cheras Business Centre  
Batu 5, Jalan Cheras  
56100 Kuala Lumpur, Malaysia  
Phone: 603-9133-4122  
email: [fareastsales@ueonline.com](mailto:fareastsales@ueonline.com)

MEXICO  
United Electric Controls  
Andador Austria 102  
Fracc. Petroquimica CP 89365  
Tampico, Tamaulipas Mexico  
Phone: 833-132-3726  
email: [latinamericasales@ueonline.com](mailto:latinamericasales@ueonline.com)

RUSSIA  
United Electric Controls, Moscow  
Kuusinena str., 19A, Office 310  
Moscow, 125252, Russia  
Phone: +7 (095) 792-88-06  
email: [russiansales@ueonline.com](mailto:russiansales@ueonline.com)



UNITED ELECTRIC  
CONTROLS

180 Dexter Avenue, P.O. Box 9143  
Watertown, MA 02471-9143 USA  
Telephone: 617 926-1000 Fax: 617 926-2568  
<http://www.ueonline.com>

SP07063500